

Power Factor Controller BR7000-1-TH for dynamical and hybrid systems

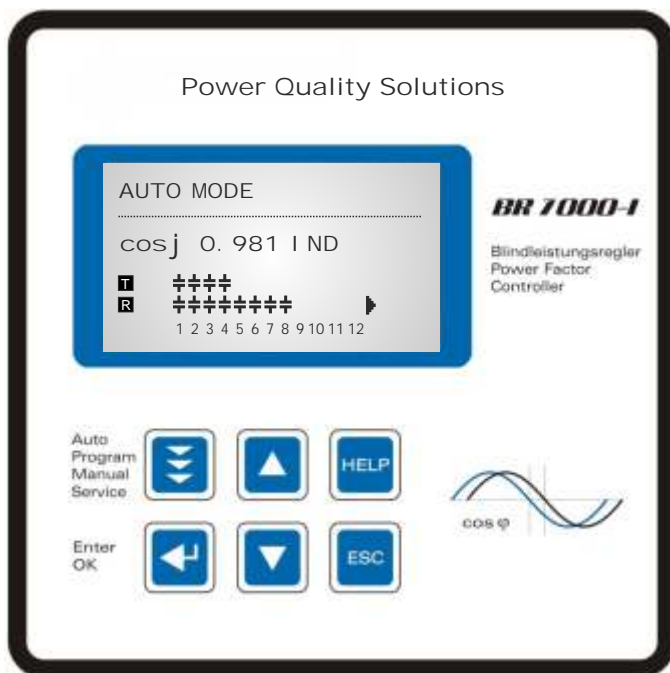

Manual

Version 2.0 - E

direct triggering of
thyristor switches TSM-LC-S
in a network possible

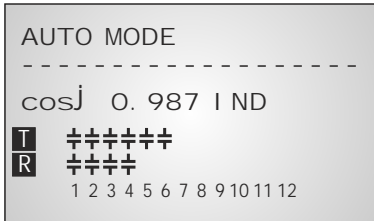

AUTO-MODE

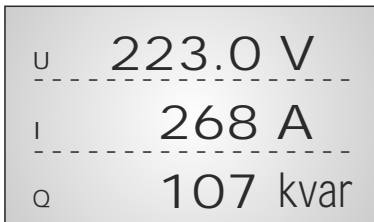

DISPLAY-MODE

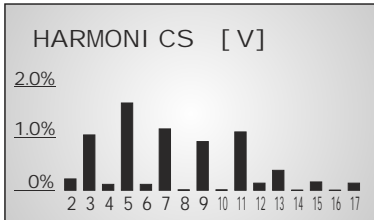

BARGRAPH-MODE

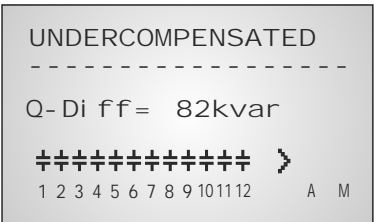

ERROR MESSAGE

CAUTIONS:

- 1. High voltage !
- 2. BR7000-1 may only be used indoor !
- 3. Make sure that the discharge time set in controller matches capacitor discharge time !



CONTENTS

Section 1	General / type series and accessories	3
Section 2	Installation of the controller / connection diagram	5
	2.1 Current measurement	6
	2.2 Programming of phase-correction	
	2.3 Error messages: Alarm- / Message relay	7
Section 3	Operating menus / modes	7
Section 4	Automatic operation / display functions	8
Section 5	Programming	
	5.1 Manual programming	9
	5.2 Programming lock	13
Section 6	Manual operation / Programming of fixed stages	14
Section 7	Service menu	15
Section 8	Expert mode	16
	8.1 Expert mode 1	
	8.2 Expert mode 2	18
Section 9	Control principle	19
Section 10	Display editor	20
Section 11	Initial operation	20
Section 12	Maintenance and warranty	20
Section 13	Interface (version /S485 only)	21
Annex:	Annex 1 Troubleshooting	23
	Annex 2 Technical data	24
	Annex 3 Table of control series	25
	Description of control-series editor	
	Annex 4 Default settings	26
	Application Anschluß von bis zu 32 TSM-LC-S über TSM-Bus	27
	Application Operating mode: dynamical compensation	28
	Application Operating mode: mixed dynamical compensation (hybrid-mode)	29
	Alarm and status notifications	30
	Handling-diagram / short reference	31

Section 1: General

The new BR7000-1-TH/S485 complements the product range of power factor controllers of the BR7000-1 series with a dynamic controller for direct triggering of thyristor modules for compensation.

As a standard the controller is equipped with 12 thyristor and 12 relay outputs and allows the realization of pure dynamic compensation systems as well as mixed-dynamic (hybrid) systems.

As a special feature the option */S485 allows the direct triggering via interface of up to 32 thyristor modules TSM-LS-S that are operating at the internal bus. In this case, the standard outputs are no longer needed – the related installation can be omitted. The bi-directional communication between controller and thyristor switches enable a direct monitoring of each single capacitor branch in real time and an enhanced control behavior depending on temperature and output. The safety of the system is increased.

The big graphic display enables a user-friendly programming and gives further benefits such as larger display in the display-mode and the display of various parameters in bargraph-mode.

With the additional "ESCAPE"-button a backward navigation in all menus is possible.

The "HELP"-button allows an interactive help in the particular menu item (German/English).

- 12 transistor and 12 relay switching outputs
- 20 pre-programmed control series with self optimized intelligent control behavior
- Control series editor for individual control series
- Operation and display completely menu-driven
- Illuminated graphic display 128 x 64 dots
- 4 quadrant operation
- Display of several grid parameters also in large letters
- Display of harmonics of voltage and current, also as bar diagram
- Display and monitoring of temperature
- Storage of maximum values of grid parameters as well as switching operations of particular capacitor contactors
- Manual/automatic operation
- Programming of fixed steps or skipping of single outputs possible
- Zero voltage switch off
- Error display of different states and alarm output (relay)
- Error storage
- Panel-mounted instrument 144 x 144 x 53 mm
- Firmware update possible

Version with interface only:

- additional external input (function programmable), e.g. for 2nd target cos-phi
- additional freely programmable message relay, e.g. for fan, status notification
- internal clock
- Serial interface RS485 (Modbus) for direct triggering of up to 32 thyristor modules TSM-LC-S – bi-directional communication with direct monitoring of each capacitor branch (monitoring of capacitor output)
- visualization, programming and data processing via PC by enclosed software

The controller is supplied as standard for an operating voltage of 110...230 VAC (+-15%), a measuring voltage of 30...440 V~ (L-N) resp. 50...760V~ (L-L) and a measuring current of 5A or 1A. A voltage converter is required for different operating voltages.



Caution!

Voltages which exceed the specified voltage range can damage the device!

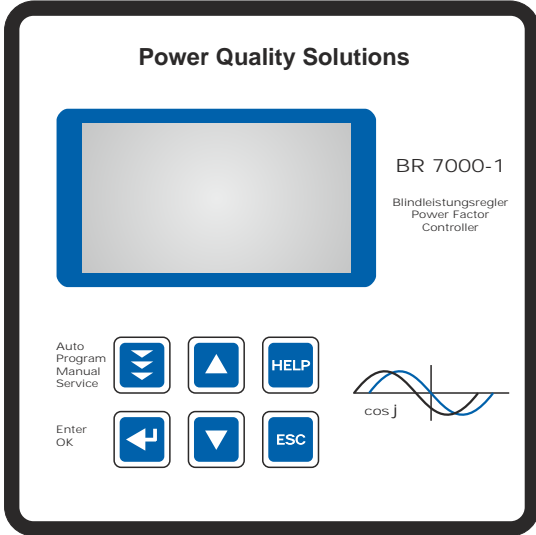

BR 7000-1-TH front view

- Operating mode:
 - Automatic
 - Program.
 - Manual oper.
 - Service
 - Expert Mode
 - Osci - Mode
 - Display Editor
- Increase selected parameter
- HELP opens Help pages



- ENTER/ OK Confirmation storage of values
- Reduce selected parameter
- Escape previous page/value in the display

BR 7000-1-TH rear view

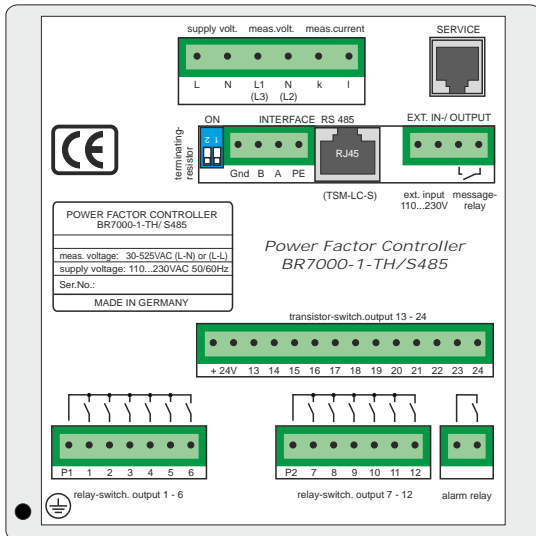

Section 2 Installation and connection of the controller

The BR7000-1 is designed to be incorporated into the front panel of a PFC-cabinet. It requires a switchboard section of 138 x 138 mm to DIN 43700/ IEC 61554. The controller is inserted from the front and is attached by means of the appended clamps. The controller may be inserted only by qualified technicians and must be operated in accordance with the specified safety regulations.

Before the device is connected up, all leads and cables must be checked to ensure that no current is flowing through them and the current converter must be short-circuited. Care should be taken to ensure that the measuring voltage and current are in the correct phase position. The measuring-current circuit must be wired with copper leads of 2.5mm². The connection should be set up as shown in the picture below. The specified safety regulations must be observed.

The measuring voltage may lie in the range from 30...440 V~ (L-N) resp. 50...760V~ (L-L) (programming of phase correction needed)

The operating voltage is 110...230 VAC +/- 15%.



The coil voltage for the capacitor contactors and the measuring voltage must be drawn from the same phase conductor, as only the measuring voltage is monitored. (Protection against direct reconnection of the capacitor contactors in the event of momentary single-phase power failure)

BR 7000-1-TH Connection plan

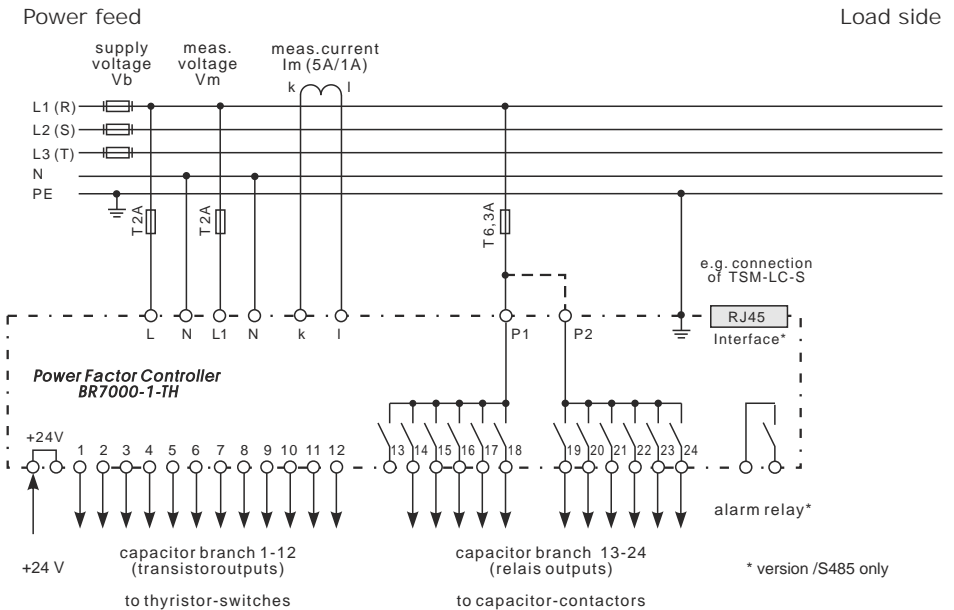

2.1 Current measurement

When installing the current converter, care should be taken to ensure that the load current and capacitor-current flows through it. The outputs of the compensation network must be installed behind the current converter (in the direction of current flow). If the BR7000-1 is connected up via sum-current converters, the overall conversion ratio is entered.

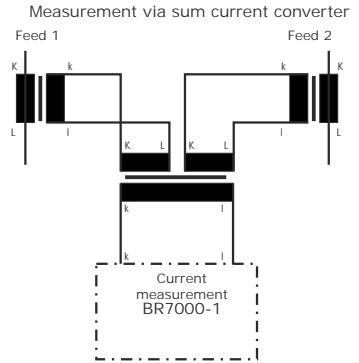

Example:

C.converter 1: 1000/5A

C.converter 2: 1000/5A

Sum-current converter: 5A+5A/5A

C.converter ratio is: 2000/5A

2.2 Programming of phase-correction - e.g. connection directly L-L (400V)

Adjustment of phase-correction between voltage and current in the meas. system is done in expert mode 1

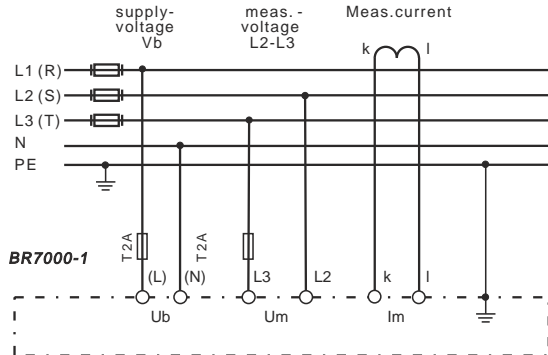

Example :

Meas.current: L1

Meas. voltage: L3-L2

Phase U/I [90°]

using	meas. current	meas. voltage	phase-angle
Preset:	L1	L1 - N	0°
	L1	L1 - L2	30°
	L1 (k<->l)	L2 - N	60°
	L1	L3 - L2	90°
	L1	L3 - N	120°
	L1	L3 - L1	150°
	L1 (k<->l)	L1 - N	180°
	L1 (k<->l)	L1 - L2	210°
	L1	L2 - N	240°
	L1	L2 - L3	270°
	L1 (k<->l)	L3 - N	300°
	L1 (k<->l)	L3 - L1	330°

2.3 Error-Messages: Alarmrelay / Message-relay*

The BR7000-1-TH is equipped with an alarm relay. Version /S485 features an additional message relay. The functions may be programmed as follows:

Alarm relay: Setting under Programming: 16 Alarm relay	Message relay: Setting under INTERFACE: 1 MESSAGE RELAY	Remark
1 OFF	OFF	
2 ERROR	ERROR	ERROR-summary report
3 ERROR inverse	ERROR inverse	List of errors in ExpertMode 2
4 FAN	FAN	ERROR: relay closed in case of error
5 Supply	Supply	ERROR inverse (factory setting):
6 Undercurrent	Undercurrent	contact open in case of error
7 Harmonic	Harmonic (THD-V)	
8 Overcompensated	Overcompensated	
9 Undercompensated	Undercompensated	
10 Warning switch. oper.	Warning switch. oper.	only relay outputs
11 Modbus-Error*	Modbus-Error	* only version -/S485
12 TSM-Error*	TSM-Error	* only version -/S485
13 C-defect*	C-defect	* only version -/S485

Adjustment and masking of all ERRORS is possible in the ExpertMode 2. The adjustment is valid for both relays.

Section 3: Menu structure / Modes

When the operating voltage is switched on, the BR7000-1-TH briefly displays its designation and software version, then changes to its normal operating status (automatic operation). The active cos-phi value is always displayed and the currently connected capacitors are shown as symbols.

- T** Transistor outputs 1 - 12
- R** Relay outputs 13 - 24

further messages compare page 30 !

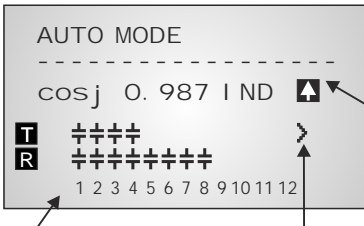

- ▶ Connecting-in
- ◀ Connecting-out
- The connecting-in arrow is always located after the maximum possible number of stages (end stop)
- An open arrow indicates that the required blocking time (discharge time) is running before an impending switching step
- ▶▶ A double arrow symbolizes fast switching of several branches

Active capacitor branches Control direction (here connected-in)

By pressing the cursor buttons, the display of capacitor stages can be changed:

Display-Mode

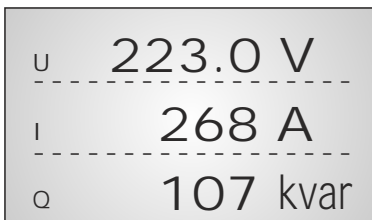

Harmonics as bar-diagram

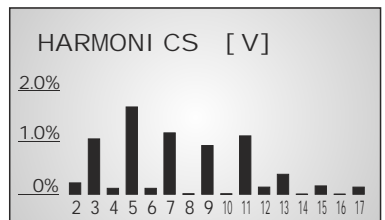

Repeated pressing of the



key takes the user to the various menus:

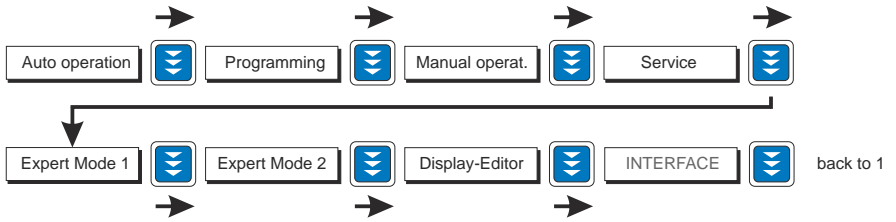

Section 4 Automatic operation - display of network parameter

The BR7000-1-TH is set to automatic operation as standard. Capacitor stages are then automatically connected in or out in order to reach the target power factor. This happens if the required reactive power is approx. 1/3 higher than the value of the smallest capacitor step.

In automatic operation, various network parameters can be displayed by repeatedly pressing the "ENTER" key:

Action	Display
ENTER	1 LINE VOLTAGE in V
ENTER	2 CURRENT A / % /reactive
ENTER	3 REACTIVE POWER in kvar
ENTER	4 ACTIVE POWER in kW
ENTER	5 APPARENT POWER in kVA
ENTER	6 DIFF. kVAR to TARGET COS
ENTER	7 FREQUENCY 50 / 60Hz
ENTER	8 TEMPERATURE in °C / °F
ENTER	9 3.-19. HARMONICS V/% I / % or as bar-chart (Selection via arrow keys)
ENTER	10 HARMONICS THD-V/%, THD-I/% relative or absolutely
ENTER	11 Compensation power in kvar
ENTER	12 ENERGY (kWh, kvarh, consumption, delivery) Reset in service: max.values reset
ENTER	13 DATE - TIME
ENTER	14 Software version
ENTER	Return to: 1

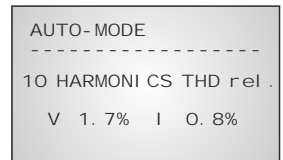
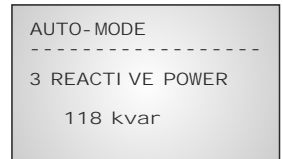

The power value specifies the total power (3-phase) assuming symmetrical load. If no key is pressed for 120 seconds, the display automatically returns to the operating status!

Under "13 Date-Time" the date format 12h/24h setting can be changed by the arrow buttons (only version -/S485).

Section 5: Programming

Pressing the  key once takes the user into the PROGRAMMING mode.

The display always shows the parameter and the set value. Values that can be edited are generally put into square brackets [].

The values are changed by pressing the keys:  

Subsequent pressing of the  key stores the value and takes the user to the next parameter.

 "ESCAPE" allows return to previous menu item.

To quit programming mode in any step, press the key: 

5.1. Manual programming (program menu)

0 LANGUAGE: This selects the language of the operating menu
(German, English, Spanish, Portuguese, French, RU, Cz, NL, PL, TR)

1 OPERATING MODE:

DYNAMICAL (standard dynamical system; max 12 steps; Appl. page 28)

HYBRID (hybrid system; 12 trans./12 relay outputs; Appl. page 29)

TSM-Bus (triggering up to 32 TSM-LC-S via TSM-bus; Appl. page 27)

TSM-Bus/Hybrid (hybrid-system max. 12x TSM-LC-S and 12 relays)

2 I-CONVERTER prim [5 ... 13000] A

This selects the primary current of the current converter.

3 I-CONVERTER sec [5 or 1] A

This sets the secondary current of the current converter.

4 END STOPP [12] for transistor outputs 1-12 (resp. 32x TSM-LC-S)

 By setting the end stopp, the number of active capacitor branches is matched to the respective capacitor bank. The visible symbols of the capacitors correspond to the connected outputs. Preset = 12

5 CONTROL SERIES [1...20 + E] for transistor outputs 1-12 (resp. 32x TSM-LC-S)

 The ratio of the capacitor branch power determines the control series, the power of the first capacitor always being assigned the value 1. If the required control series should exceptionally not be present (Annex 3), the user may define a special one (control series "E"). More on this point in the control-series editor in Annex 3.

6 CONTROL PRINCIPLE (for transistor outputs 1-12)

 The control preference may be selected here:

- SEQUENTIAL connection

- LOOP connection

- INTELLIGENT loop connection (default setting)

See Section 9 for an explanation of the various control principles.

7 POWER 1. STAGE [0,01...255,99] kvar for transistor-outputs 1-12

T To determine the controller's response sensitivity, the dimensions of the network's smallest capacitor (stage 1) must be known. They are entered in two steps in kvar. The integral kvar values (before the comma) are initially selected via the \uparrow / \downarrow keys and saved with ENTER. The positions after the comma are then selected, again via the \uparrow / \downarrow keys. If the response sensitivity is being undercut, a warning will occur (indication of "!" in the display)
Switching over the range up to 25500 kvar in ExpertMode 1!

8 TARGET COS PHI [0.1 ind...0.1 cap] or TAN PHI [9.0 IND... 9.0 CAP]
By setting the target cos phi, the power factor to be attained via the PF correction is defined. It is also set via the \uparrow / \downarrow keys.
Switch-over COS/TAN PHI in the ExpertMode 1: 17 DISPLAY

9 TARGET COS PHI 2 (only available, if in „Interface“ / 3 External input selected)
Input of 2nd target-cos Phi

10 MEAS. VOLTAGE [30...760]V
Programming the measuring voltage of the system.
The values programmed here always refer to the voltage at the clamps of the device!

11 V - CONVERTER RATIO [NO / 230V ... 380kV]
When a measuring-voltage converter (e.g. for HV-measurement) is used, its conversion ratio should be programmed here.
(Input of prim.voltage is here, sec. voltage is automatically from item 10)

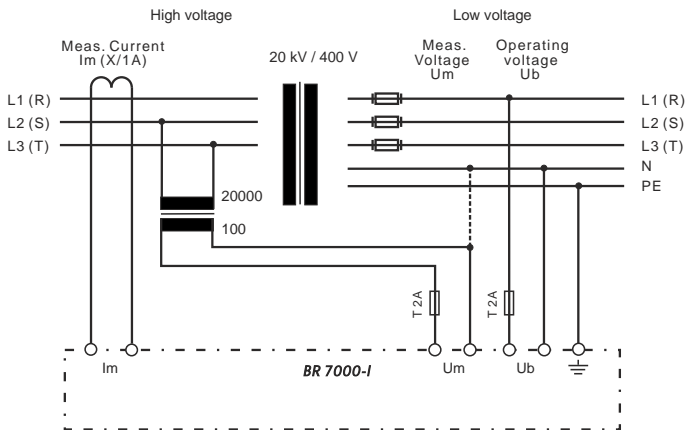

12 FREQUENCY (50Hz / 60Hz)
Selection of used grid-frequency

13 CONNECTING TIME (for transistor outputs 1-12)



This refers to the time between connecting the capacitors to increase the momentary network capacitance. It should be noted that in practical operation the real connection time is affected by the discharge time (locking time).

Setting range: 20 ms ... 1 sec. Default setting: 1 sec.

14 DISCONNECTING TIME (for transistor outputs 1-12)



This refers to the time between disconnecting the capacitors to reduce the momentary network capacitance.

Setting range: 20 ms ... 1 sec. Default setting: 1 sec.

15 DISCHARGE TIME (for transistor outputs 1-12)



This is the time for which an individual output is blocked between connecting and disconnecting. This blocking time has priority over connecting and disconnecting times. It depends on the capacitor discharge rating and thus is specified by the compensation network.

Setting range: 20 ms ... 1 sec. Default setting: 1 sec.

16 ALARM TEMP [40...85]°C

The alarm temperature programmed here is the temperature at which the capacitor stages are disconnected in steps. The controller's alarm relay responds after ten minutes. (factory settings) At the same time the display shows the cause of the alarm (over-temperature). If the temperature drops again, the required branches are automatically re-connected in steps.

Factory setting: 55°C

17 ALARM RELAY

can be programmed here for one of the following functions:

ERROR = Summary report

1	OFF	
2	ERROR	contact closed in case of error (except voltage sag)
3	ERROR inverse	contact open in case of error (factory setting) ERROR resp. ERROR inverse is a collective report and includes the following errors: Overtemperature, Meas.voltage, Overvoltage, Undervoltage, Over- Undercompensated, Overcurrent, Harmonics, Warning switching operations
4	FAN	for external fan Parameterization under "18 FAN temperature"
5	SUPPLY	Message when real-power is supplied
6	UNDERCURRENT	Measuring current below minimum
7	HARMONIC	Exceeding of THD-V limit value (7%) Parameterization under "19 Harmonics"
8	OVERCOMPENSATED	
9	UNDERCOMPENSATED	
10	Warning switch. oper.	Exceeding of set switching operations value
11	MODBUS-ERROR	only version -/S485
12	TSM-ERROR	only version -/S485
13	C-DEFECT	only version -/S485

18 FAN TEMP * [15...70]°C
Input of the switching threshold for the fan
* Only active if option „Fan“ is selected

19 HARMONICS (harmonic limit) [OFF or 0.1 -25.5]%
A limit for the total harmonic distortion THD-V (in%) can be entered here. When this threshold is exceeded, a message is given. THD-V is the ratio of the geometric sum of the harmonics to the fundamental. Factory setting: OFF

20 HARMONICS
selection of harmonics for bar graph-display in display-mode
[3. 5. 7. - 19.] Odd up to 19th (factory setting)
[3. 5. 7. - 33.] Odd up to 33th
[2. 3. 4. - 17.] Even and odd up to 17th

21 CONTRAST
Adjustment of optimal contrast for the display possible

R 22 END STOPP [12] for relay outputs 13-24

R 23 CONTROL SERIES [1...20 + E] for relay outputs 13-24

R 24 CONTROL PRINCIPLE for relay outputs 13-24

R 25 POWER 1st STAGE [0.01 - 255.99] kvar for relay outputs 13-24

R 26 CONNECTING TIME for relay outputs 13-24
setting range: 1 ... 255 sec.
factory setting: 40 sec.

R 27 DISCONNECTING TIME for relay outputs 13-24
setting range: 1 ... 255 sec.
factory setting: 40 sec.

R 28 DISCHARGE TIME for relay outputs 13-24
setting range: 1 ... 255 sec.
factory setting: 60 sec.

BASIC SETTINGS: [NO] (YES / NO)
When the selection is made with YES and confirmed with ENTER, all parameters are reset to the basic setting made by the PFC-system manufacturer. (Optimal network values when the controller was supplied with a complete PFC-system). If the controller is supplied from the works, this point corresponds to the default setting.

CAUTION: All user settings are lost!

5.2 Programming lock

The BR7000-1-TH is equipped with a programming lock to ensure protection from unauthorized or inadvertent changes to the system parameters. The lock can be activated in expert mode.

If the lock is active, all parameters can be checked but not changed.

Section 6: Manual operation (initial operation, maintenance, service)
 Programming of fixed stages

In manual mode1 , capacitor branches can be connected/disconnected in the set control series and switching time - irrespective of prevailing power-line conditions. The starting condition is STOPP (no stages connected). Connections are made by pressing the **↑** key (CAP ON). Pressing **↓** initially leads back to STOPP mode. Repeated pressing of **↓** leads to the disconnection of stages (CAP OFF). The active operating status and active power factor are always shown on the display (self-explanatory).

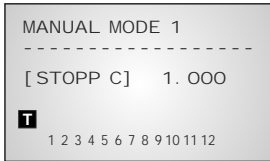

device stopp

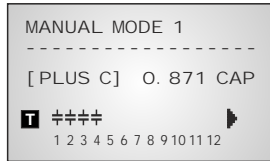

connection of steps

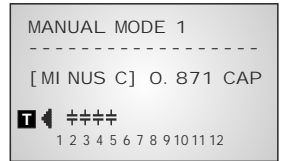

disconnection of steps

Pressing ENTER takes the user to the menu point "manual mode 2". Normally, all stages are programmed for automatic operation (default setting).

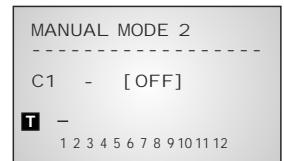
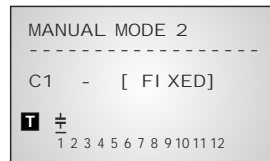
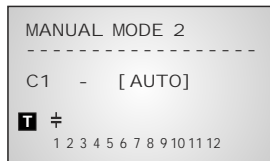

In special cases, the controller outputs (C1-C12) **T** resp. in hybrid-mode (C13-C24) **R** may be permanently defined in succession (continued switching via ENTER) for the following statuses:

- AUTO: Automatic (normal) operation
 The relevant output is marked by a capacitor symbol.
- FIXED: The output is continuously connected, e.g. for fixed PFC. The output is marked by an underlined capacitor symbol.
- OFF: The output is continuously disconnected - e.g. for temporarily disconnecting a defective capacitor. The capacitor symbol for this output is faded out. Minus (-) appears.

The active stage is blinking. The required status is set via **↑** / **↓**. By pressing ENTER, the user saves this step and moves to the next stage. The programmed statuses for the outputs also remain visible on the display in automatic operation.

After the required settings have been made, pressing the "Operating Mode" key takes the user to the next menu ("Service") or further to "Automatic Operation".

Section 7: Service menu

The service menu is reached by the operating-mode key. 

The stored maximum values of the network parameters can be displayed here as well as the number of switching operations of the individual capacitors and their operating time. (only relay-stages) The desired stages can be selected via the arrow keys.



In version /S485 the max. values are stored including time-stamp!

In addition, a fault memory is available, in which the last 100 fault states of the system are stored with fault code and in plain text. (This allows, for example, capturing short lived events of overtemperature or overvoltage)

Action	Display
ENTER	1 min/max VOLTAGE in V
ENTER	2 max. CURRENT in A
ENTER	3 max. REACTIVE POWER in kvar
ENTER	4 max. ACTIVE POWER in kW
ENTER	5 max. APPARENT POWER in kVA
ENTER	6 max. TEMPERATURE in °C /°F
ENTER	7 max. THD - V / THD-I in %
ENTER	8 MAX. VALUES RESET
ENTER	9 ERROR MEMORY ... Plain text
ENTER	10 ERROR MEMORY RESET
ENTER	11 SWITCH. OPERATIONS only relay stages
ENTER	12 OPERATING TIMES only relay stage
ENTER	back to 1

Section 8.1 Experten mode 1

The expert mode is meant for the adjustment of values which normally should not be changed. As a protection against mal-operation this level has an access code.

Factory setting: "6343" The password can be changed in point 18 of expert mode 1.

- 1 PASSWORD ???? (Factory setting: 6343)
- 2 BASIC SETTING NEW [NO] (available: NO/YES)
Storage of active programming as a new basic setting
(usually performed by the PFC-system manufacturer)
Caution: The original values are overwritten in the process!
- R** 3 SWITCHING OPERATION RESET [NO] (available: NO/YES)
The switching operations of relay outputs are reset to zero.
(Reset of individual stages in Expert-Mode 2)
- R** 4 OPERATING TIME RESET [NO] (available: NO/YES)
The stored operation times of relay outputs are reset to zero.
(Reset of individual stages in Expert-Mode 2)
- T** 5 SWITCHING POWER max [100] kvar (multiples of the smallest stage)
for transistor-outputs
This factor specifies the maximum power which may be switched in one switching step. It can be used to control the intelligent control system, which switches several stages as a function of the power-factor requirement.
(Factory setting: 4 times the power of the first stage)
- R** 6 SWITCHING POWER max [100] kvar (multiples of the smallest stage)
for relay outputs
(Factory setting: 4 times the power of the first stage)
- 7 SWITCH. TRIGGER IND [66]% (30...100%)
Threshold for switching ON of next stage (a-value)
- 8 SWITCH. TRIGGER CAP [66]% (30...100%)
Threshold for switching OFF of next stage (b-value)
- 9 OPERATING LOCK [NO] (NO / YES)
- R** 10 SWITCH. OPERATION WARNING [50 000] (1000 ... 255000)
for relay outputs only
After a relay-output has performed this number of switching operations, a warning message is displayed. (Abrasion of capacitor contactors and capacitors)
- R** 11 HYBRID-SYMMETRIE [100]% (50...100%)
Percentage of dynamically switches system output that is replaced (taken over) by contactor switched steps (power transfer dynamic)

- 12 PHASE I 0° Adjustment of current phase position
Selection of phase of current transformer
- 13 PHASE V 0° Adjustment of voltage phase position:
Between which conductors has the measuring voltage of
the controller been connected:
L-L resp. L-N of all phases possible.
- Phase correction between voltage and current in the measuring system. (refer p.6)
- 14 OUTPUT 1. STEP [0...255] (0...2550; 0...25500)
The range for entering the stage output can be increased to [0...25500] here
(e.g. for high-voltage measurement)
- 15 CONTROL [3] PHASE (3 / 1)
The measuring system of the controller is based on a single phase measurement.
3-phase (factory setting): The measurement is converted and all outputs are
displayed 3-phase (presuming symmetry in the grid).
1-phase: Display and control is only performed for the measured 1-phase value
(for example 1-phase compensation in non-symmetric grids)
- 16 SUPPLY Setting of the controller in case supply of electric power takes place
(1) --- (no reaction) factory setting
(2) switch off stepwise
(3) total switch off
(4) controls for 2nd target cos-Phi
- 17 DISPLAY [cos j] (cos j / tan j)
Switch over between cosinus or tangens j in the display (all menus)
- 18-22 PASSWORD?
The password for ExpertMode can be changed here. All combinations of letters
and figures are possible
- 23 ERROR-DISPLAY BACKLIGHT
If an error or warning message appears in the display - the backlight can change
to red light for better attention. Here a modification is possible.
(OFF/ white / red/ pink)

Section 8.2. Expert mode 2

The additional 2nd expert mode includes all messages for operation, warning and error which are displayed by the BR7000-1-TH. Here they may be deactivated separately. When deactivated, the indication of the message in the display as well as possible activation of the relay or effects on the control behavior are suppressed. The programming of a delay-time for messages is possible here. Additionally, switching operations and operation times of the capacitors can be reset. (only relay-stages)

- 1 PASSWORD ???? (Factory setting: 6343)
Changing of code is possible in ExpertMode1 / item 18

Activation / Deactivation / Delay time of particular warnings and error-messages - s. above:

Meas.-voltage; Overvoltage; Overcompensated; Undercompensated; Harmonics!; Overtemperature; Overcurrent; Undervoltage; Switch.Operations!; meas.current; Modbus-Error; TSM-Error; MODBUS-remote; System current<; BusError extern; C-defect; System current>; Overload equip.; External Error; C-Error Off

- 2 ERROR ME.RELAY [10] min. (1...255 min.)
Time after which the alarm relay will respond
- 3 UNDERVOLTAGE [50] % (20...100%)
meas. voltage below this threshold will switch OFF all stages at the same time
- 4 OVERVOLTAGE [130] % (105...140%)
meas. voltage above this threshold will switch OFF the stages step by step.

If the measure voltage returns to the permissible range, the stages will switch ON again.

- R** 5 SWITCH. OPERATION C13 RESET [NO] (YES / NO)
16 to C24 RESET [NO] (YES / NO)

Reset of switching operations of relay outputs possible, e.g. after replacement of particular capacitors or contactors

- R** 17 OPERATION TIME C13 RESET [NO] (YES / NO)
28 to C24 RESET [NO] (YES / NO)

Reset of operation time of relay outputs possible, e.g. after replacement of particular capacitors

Section 9 Control principle

The control response of the BR7000-1-TH can be selected in programming mode.
(for dynamical part and relay part separately)

The controller has the following different control modes:

1. Sequential connection

In sequential connection, the required capacitor stages are successively connected and disconnected in stages (last in - first out). The ranking of each step always corresponds to the power of the smallest stage.

Advantage: Exact definition of the next capacitor to be connected in each case

Disadvantage: Long settling time, high switching frequency of the small stages

In order to shorten the settling time, the controller switches several stages simultaneously for a large power-factor requirement. This applies to all control types. The maximum dimensions of the simultaneously switching branches can be changed in expert mode. If the value of the smallest stage is pre-selected, the conventional sequential connection is obtained.

2. Loop connection

In this variant, the controller operates in loop mode (first in - first out) which minimizes the wear on the capacitor bank, i.e. where stages are of equivalent dimensions, the stage which was disconnected for the longest period of time is always connected next.

Advantage: Balanced utilization of equivalent stages and thus an increased operating life of the capacitor bank.

Disadvantage: This mode can only be used in control series with groups of the same stage power and long settling time, as every switching step corresponds to the value of the smallest stage.

3. Intelligent loop connection (default setting)

The intelligent control principle combines the advantages of the network-sparing loop connection (first in - first out) with a much faster settling time, even for large load skips, and reaches this goal with the fewest possible switching operations of the capacitor stages. The optimized time response is achieved by the simultaneous switching of several or larger capacitor groups as a function of the missing power factor in the power line. Both the number of real switching frequencies of the capacitors as well as the turn-on times of the branches are considered.

Advantage: Reaches the target cos phi in a fast-optimized settling time with a low switching frequency of the capacitors.

The particular capacitor steps are permanently monitored. In case of a defect capacitor or higher deviation from the nominal output the capacitor will be displayed inverted.

Section 10 Display-Editor

The Display-editor is reached by activation the operation button.

In the Display-editor a selection of measuring values can be performed which shall be displayed in the Display-mode.

Out of the available measuring values shown below 3 values can be selected sequentially which then are available in the Display-mode as large letters. Selection is done by the arrow-buttons, confirmation with ENTER:

- 1 Grid voltage
- 2 Apparent current
- 3 Reactive power
- 4 Active power
- 5 Apparent power
- 6 Difference reactive power
- 7 Frequency
- 8 Temperature
- 9 THD-V
- 10 THD-I
- 11 Cos Phi
- 12 Tan Phi
- 13 --- (no display)

DI SPLAY - EDI TOR

1. DI SPLAY [1]

[LI NE VOLTAGE]

Example: Display in DISPLAY-MODE

Selected parameters:

1. Grid voltage
2. Apparent current
3. Reactive power

U 223.0 V

I 268 A

Q 107 kvar

Note:

Even in Display-Mode the BR7000-1-TH will continue to operate as P.F.controller in the background with all functions programmed!

Section 11 Initial operation

The controller must have been installed before being set up and operated.

All network-specific parameters are fully programmed as described in section 5 (Programming) by being entered in sequence and stored. The controller is then set to automatic operation with the operating mode key. It is now ready for operation.

Section 12 Maintenance and warranty

The BR7000-1-TH should need no maintenance if the operating conditions are observed. However, it is recommended that a functional check of the controller be performed in conjunction with the regular checking of the capacitor bank. In the event of any interventions in the controller during the warranty period, all warranty claims lapse.

Section 13: Menu INTERFACE

The BR7000-1-TH is optionally equipped with a RS485-interface, an internal clock, a potential free external input (110 ... 230 V) and an additional message relay. Therefore the following functions are only available for version /S485:

1 MESSAGE RELAY [1]

Functions and settings see section 2.3 Error messages (p.7)

2 FAN TEMPERATURE

Input of switching threshold, when message relay = FAN has been selected.

3 EXTERNAL INPUT

The function of the external input (110..230 V) can be selected here:

[0] - OFF

[1] - 2nd target cos-Phi

this will activate the 2nd target cos-Phi

[2] - EXTERNAL ERROR

In this operation mode the activation of the input causes a controlled switch off of all steps (remote switch off)

4 ... 8 Adjusting of internal clock (hour, minute, date)

9 PROTOCOL

[0]	-----	OFF
[1]	MODBUS KTR	
[2]	MODBUS RTU	Modbus-protocol for individual usage
[3]	ASCII OUT	Transmitting of grid-values as ASCII-Data, permanent sequential output of: U, I, Q, P, S, switched steps (display "XXX-----" means 3 active steps)
[4]	TSM-LC-S	this selection is made automatically in „operation-mode“: TSM-BUS

Depending on the selected protocol the following settings may be partially deactivated:

10 BAUD RATE	Baudrate 9600...256000 adjustable Parity NONE, ODD, EVEN selectable
11 ADDRESS	[1] (1...255)
12 ASCII transmit.interval	[10] sec. (1...255) Repeat time ASCII transmission
13 SEPARATOR	(for ASCII protocol) Selection HT; LF/CR; SP; CR/LF; Minus; CSV
14 LIMIT VALUE (-)	[50] % (10... 90)% Power limit value TSM-LC-S
15 LIMIT VALUE(+)	[130] % (105...200)%
16 TEST TIME	[20] sec. (1...255) sec. Error delay time TSM-LC-S
17 BLOCKING TIME	[60] sec. (0...255) sec. Delay time after which the TSM-LC-S is switched on again after it has been switched off due to overload

Following functions can be realized via the interface:

- direct bidirectional controlling of up to 32 thyristor-switches TSM-LC-S
- Parameterization of the controller via PC
- Remote read out of grid parameters, storage and display via PC-software BR7000-SOFT
- Connection of system accessory (e.g. datalogger)

Instructions for bus wiring when using the interface

- For bus wiring screened cable has to be used!
- The bus wirings (incoming and outgoing leads) always have to be applied directly to the device (no branch boxes)!
- In the devices at the end of the busses the terminating resistors integrated in the device have to be activated (DIP-switch ON).

Connecting plan INTERFACE:

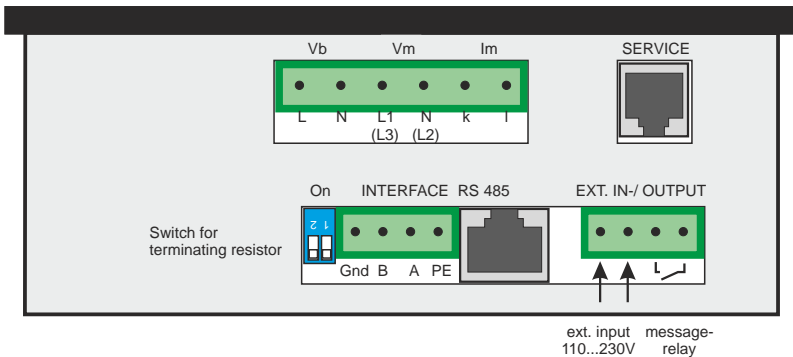

Annex 1: Troubleshooting

Fault	Check / Solution
<p>At target $\cos \phi = 1$ and inductive load, switch-off or connection of capacitor in the corrected line Supply / Drawing mismatched Wrong line $\cos \phi$ is displayed</p>	<p>Check terminals of the measuring voltage and current (l and k)! Check phase position</p>
<p>Display: "UNDER CURRENT"</p>	<p>Current in measuring range? Line interruption? Wrong current-converter factor? Current transformer short-circuited?</p>
<p>Display: "OVERCURRENT" Alarm relay: after 10 min.</p>	<p>Check current-converter ratio Go through measuring current range</p>
<p>Display: "UNDERCOMPENSATED" Alarm relay: after 10 min.</p>	<p>Check connection and phase position! All stages connected - target $\cos \phi$ not reached: compensation network sufficiently dimensioned?</p>
<p>Display: "OVERCOMPENSATED" Alarm relay: after 10 min.</p>	<p>Check connection and phase position! Capacitive grid, although all stages disconnected</p>
<p>Display: "MEASUREMENT VOLTAGE ???" Alarm relay: after 10 min.</p>	<p>No measurement voltage!</p>
<p>Display: "OVERTEMPERATURE" Alarm relay: after 10 min.</p>	<p>Cabinet temperature too high: Outputs are switched off in stages irrespective of power-line conditions</p>
<p>Stages are disconnected for an inductive line or connected for a capacitive line</p> <p>The controller does not connect all stages, or $\cos \phi$ does not change at the last stages</p> <p>In automatic operation, individual stages are not connected or disconnected</p>	<p>If a target $\cos \phi$ is set which deviates from 1 despite an inductive line load, the display < (disconnect stages) may light up. The arrows indicate the control direction and not the line conditions.</p> <p>Check END STOPP !</p>
<p>In strongly asymmetrically loaded lines, differences may occur between control response and power-factor measurement, as the power factor is measured in single phase.</p>	<p>Line measurements allow the most favorable phase for measuring the power factor to be determined. The current converter is set accordingly for the measuring current.</p>
<p>No operating voltage</p>	<p>Note: No display</p>

Annex 2: Technical data

Type series	BR 7000-1-TH
Outputs *version /S485:	12 relay / 12 transistor / alarm-relay message relay* / interface*
Languages	D / E / ES / RU / NL / CZ / PL / F / PT / TR
Switching power of relay outputs	250VAC, 1000W
Switching power of transistor outputs	24VDC, ca. 40mA for controlling TSM
Number of active outputs	programmable 2 x 12; resp. 32 pcs. @ TSM-Bus
Display	illuminated graphic display 128x64 dot LCD-Display: white / red lighted
Number of control series	20
User defined control series	1
Control principle	Sequential connection, loop connection or self-optimized switching response Four-quadrant operation
Operating voltage	110...230 VAC, +/-15%, 50 / 60Hz
Measuring voltage	30...440 V~, (L-N) bzw. 50...760V~ (L-L)
Measuring current	X: 5 / 1A selectable
Power drawn	ca. 3 VA
Sensitivity	20 mA
Target cos Phi	0.1 inductive to 0.1 capacitive adjustable
Connecting time	T: 20 ms - 1 sec. / R: 1 - 255 sec.
Disconnecting time	T: 20 ms - 1 sec. / R: 1 - 255 sec.
Discharge time	T: 20 ms - 1 sec. / R: 1 - 255 sec.
Fixed stages / skipped stages	Programmable
Alarm relay	Standard
No-voltage triggering	Standard
Display of power-line parameters	Power factor, voltage, apparent current, frequency, reactive-, active-, apparent power, missing kvar, temperature, harmonics
Storage of maximum values	Voltage, reactive power, active power, apparent power, temperature, THD-V, THD-I
Storage of switching number	Yes, each relay output, individual reset possible
Storage of operating time	Yes, each relay output, individual reset possible
Temperature measurement range	-30°C ... 100°C
Error memory	last 100 error states are stored
Accuracy	Current / voltage: 1% Reactive-, active-, apparent power: 2%
Housing	Switchboard-integrated housing DIN 43 700, 144 x 144 x 53 mm
Weight	1 kg
Operating ambient temperature	-20 bis +60°C
Protection type to DIN 40 050	Front: IP 54, Rear: IP 20
Safety guidelines	IEC 61010-1:2001, EN 61010-1:2001
Sensitivity to interference (industrial areas)	EN 50082-1:1995 IEC 61000-4-2: 8kV; IEC 61000-4-4: 4kV

Annex 3: Table of control series

No.	Control series	Loop connection
1	1 : 1 : 1 : 1 : 1 : 1 : 1 : 1 : 1 : 1 : 1 : 1	Possible
2	1 : 2 : 2 : 2 : 2 : 2 : 2 : 2 : 2 : 2 : 2 : 2	Possible
3	1 : 2 : 3 : 3 : 3 : 3 : 3 : 3 : 3 : 3 : 3 : 3	Possible
4	1 : 2 : 3 : 4 : 4 : 4 : 4 : 4 : 4 : 4 : 4 : 4	Possible
5	1 : 2 : 4 : 4 : 4 : 4 : 4 : 4 : 4 : 4 : 4 : 4	Possible
6	1 : 2 : 3 : 6 : 6 : 6 : 6 : 6 : 6 : 6 : 6 : 6	Possible
7	1 : 2 : 4 : 8 : 8 : 8 : 8 : 8 : 8 : 8 : 8 : 8	Possible
8	1 : 1 : 1 : 1 : 2 : 2 : 2 : 2 : 2 : 2 : 2 : 2	Possible
9	1 : 1 : 1 : 1 : 1 : 6 : 6 : 6 : 6 : 6 : 6 : 6	Possible
10	1 : 1 : 2 : 2 : 2 : 2 : 2 : 2 : 2 : 2 : 2 : 2	Possible
11	1 : 1 : 2 : 2 : 2 : 4 : 4 : 4 : 4 : 4 : 4 : 4	Possible
12	1 : 1 : 2 : 2 : 4 : 4 : 4 : 4 : 4 : 4 : 4 : 4	Possible
13	1 : 1 : 1 : 2 : 2 : 2 : 2 : 2 : 2 : 2 : 2 : 2	Possible
14	1 : 1 : 2 : 3 : 3 : 3 : 3 : 3 : 3 : 3 : 3 : 3	Possible
15	1 : 1 : 2 : 4 : 4 : 4 : 4 : 4 : 4 : 4 : 4 : 4	Possible
16	1 : 1 : 2 : 4 : 8 : 8 : 8 : 8 : 8 : 8 : 8 : 8	Possible
17	1 : 2 : 2 : 3 : 3 : 3 : 3 : 3 : 3 : 3 : 3 : 3	Possible
18	1 : 2 : 3 : 4 : 4 : 8 : 8 : 8 : 8 : 8 : 8 : 8	Possible
19	1 : 2 : 2 : 4 : 4 : 4 : 4 : 4 : 4 : 4 : 4 : 4	Possible
20	1 : 2 : 2 : 2 : 4 : 4 : 4 : 4 : 4 : 4 : 4 : 4	Possible
"E"	Control-series editor	Possible

Control -series editor (programming up to a rating of 30)

The control-series editor allows the user to simply define his/her own control series if the required control series is not available for any reason. The last control series - Control Series E - is selected by pressing the "Programming" key (point 5 resp. 23: Control series) and confirmed with ENTER. This leads to the insertion of an additional menu point in the main menu -> the control-series editor. It may be reached via the "Operating Mode" key.



In the control-series editor, all stages can be set in succession to the desired value with the selection keys \uparrow / \downarrow . The next stage in each case is reached by pressing ENTER. In the control series editor, the various steps may be programmed up to a rating of 30 (!). The rating >9 is indicated in the display as follows: 10=A, 11=B, 12=C, 13=D, 14=E, 15=F, 16=G 30=U

ALL control series can be generated (even downwards). The customer will decide whether the generated control series is of sense.

The maximum number of stages can be limited by a programmed END STOPP < 12.

Annex 4: Default settings

Note: The following values for the default settings apply only if the controller is supplied directly from the manufacturer. Otherwise, these values may have been replaced by settings made by the manufacturer of the compensation network (optimal values for the relevant network).

Nr.	Parameter	Default setting	Programmed values of this system (to be entered by manufacturer or operator)
0	LANGUAGE	ENGLISH	
1	OPERATING MODE	DYNAMICAL	
2	I CONVERTER prim.	1000 A	
3	I CONVERTER sec.	5 A	
4/22	END STOPP	12 / 12 (T / R)	
5/23	CONTROL SERIES	1 / 1 (T / R)	
6/24	CONTROL PRINCIPLE	INTELLIGENT	
7/25	POWER 1. STAGE	25,00 kvar (T / R)	
8/9	TARGET COS-PHI	0,98 IND (T / R)	
10	MEASURING VOLTAGE	230 V L-N	
11	V - CONVERTER RATIO	- NO -	
12	FREQUENCY	50 Hz	
13/26	SWITCH-IN TIME	1 / 40 sec. (T / R)	
14/27	SWITCH-OFF TIME	1 / 40 sec. (T / R)	
15/28	DISCHARGE TIME	1 / 60 sec. (T / R)	
16	ALARM TEMP.	55° C	
17	ALARM RELAY	ERROR INV.	
18	TEMP. FAN ON	30° C	
19	HARMONICS THD-V	----	
20	HARMONICS bar diagram	3. - 19.	
21	CONTRAST	4	
	Capacitor stages Password Expert-Mode 1 Password Expert-Mode 2 Switch.trigger IND / CAP	AUTO 6343 6343 66 %	
	Max.simult.switch.power Operating lock Switch.operations warning Phase-shifting V/I Power 1st stage Control Display power-factor Protocol* Baud rate* Adress* ASCII transmit. interval*	4 x smallest stage - NO - 50.000 (R) 0° 0 ...255 kvar 3-phase Cos Phi Modbus-RTU 9600/None 1 10 sec.	
			* version with interface only

Application: TSM-BUS

Connection of up to 32 thyristor-switches TSM-LC-S via TSM-Bus;
bidirectional communication

This operation mode supports the connection of up to 32 thyristor modules TSM-LC-S at the interface RS485. Due to the bi-directional communication a new quality of the system is achieved. With the interface the values of each capacitor branch is monitored in real time and used for controlling

For the power supply of each 10 TSM-LC-S one feed-in module ESP24 (available as accessory) is needed which is directly looped into the bus connection (24 V DC required).

The potential free overtemperature switch of the filter reactor can be connected directly at the particular TSM-LC-S and is proceeded for error messages resp. switching off of the step.

The display of values of the single TSM modules at the controller is done in the main menu (display) by button \uparrow . In the display the actual values of capacitor current, status, temperature and voltage are shown.

\uparrow browses to the next module connected.

Error messages of the modules are directly displayed in the step display of the main menu instead of the capacitor symbol. Possible failures s. page 30. (B,C,M,T,P,E)

The programming of the system (end stop, control series...) is done in the programming menu like a regular dynamic system. Only the address (= number of the step) has to be programmed.

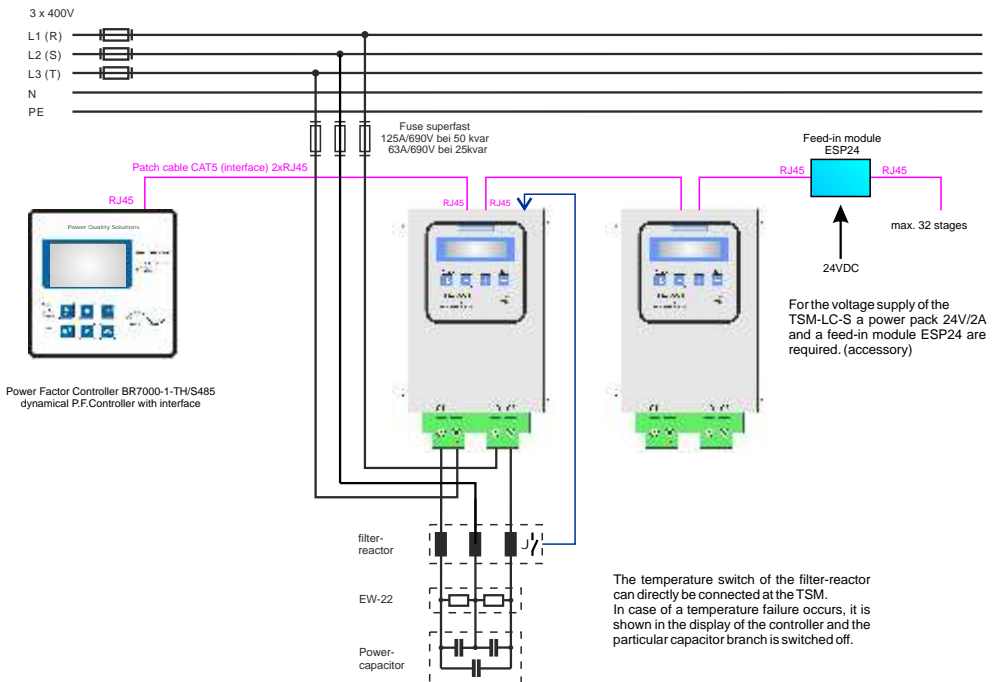

Application

Connection /Operating mode: Dynamical compensation

In this operation mode the BR7000-1-TH works as a dynamic power factor controller. Maximum 12 thyristor outputs are available for direct triggering of thyristor modules TSM-LC...

Existing relay outputs and the menu items that are not needed are deactivated.

For the triggering of the thyristor modules an external voltage supply 24 V/1 A is required (input current of a TSM: approx. 20 mA).

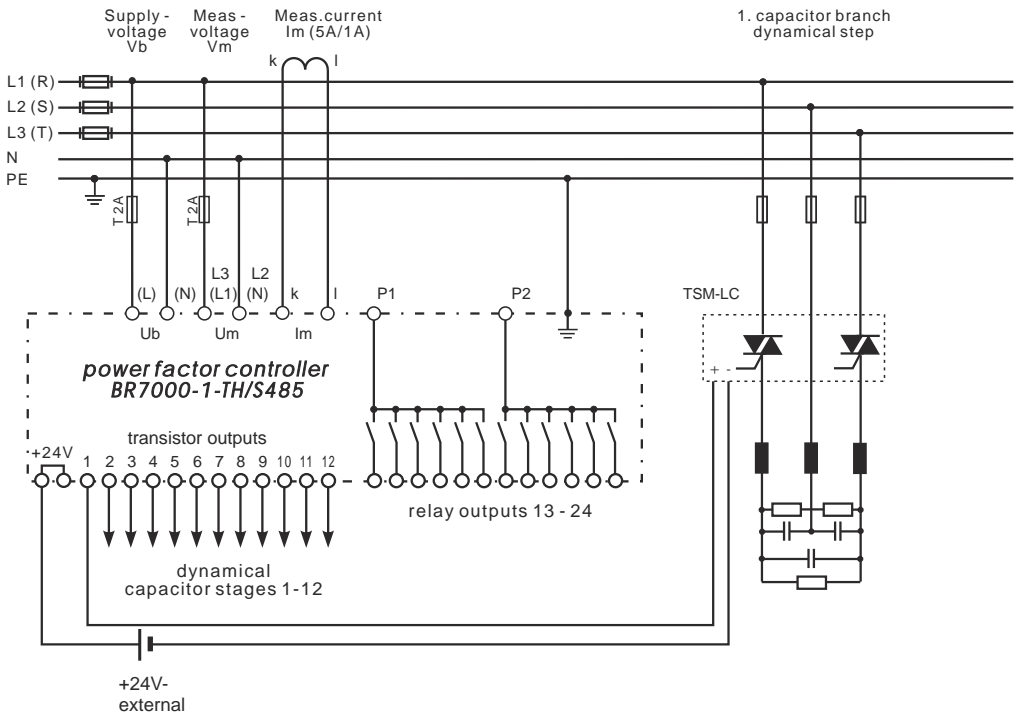

Application

Connection / Operating mode: Mixed-dynamical compensation (Hybrid)

Mixed dynamic systems feature the advantages of dynamic systems, but can be offered at a cost effective price. (Fast changing loads are dynamically compensated, ground loads and slowly changing loads are compensated conventionally)

The operating mode „HYBRID-MODE“ has especially be designed to these cases. It supports up to 12 thyristor outputs (for switching of thyristor modules) and 12 relay outputs (for switching of capacitor contactors).

The parameter control series, end stop, control principle, switching times and priorities can be separately programmed for thyristor and relay part.

For triggering of thyristor modules an external power supply 24 V/1A is required (input current of a TSM: approx.. 20 mA)

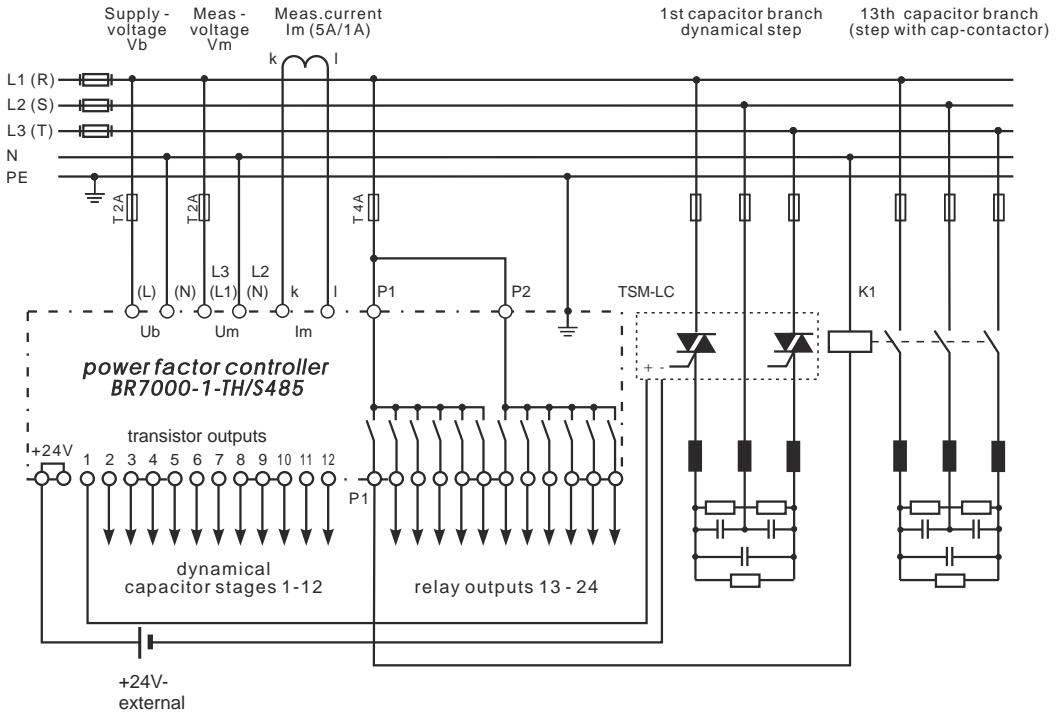

Alarm- and status messages in the display

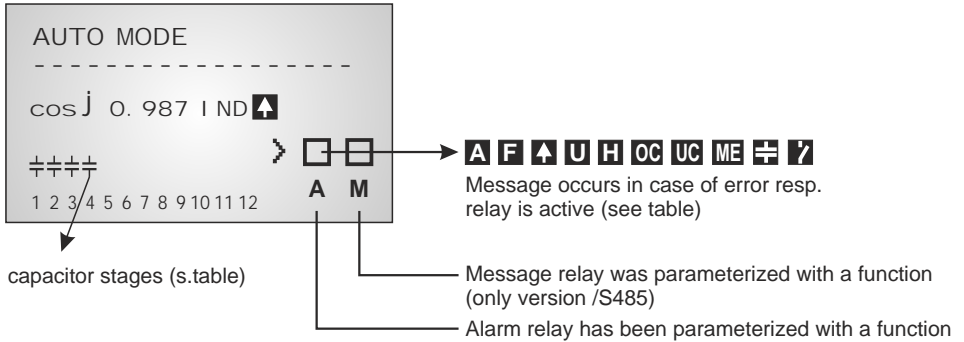

Display of capacitor-stages:

- B** Bus-Error
- C** CRC-Error
- M** Module error
- T** Overtemperature TSM
- P** Power of stage too high
- ⚡** C - defect
- E** Step Error

Display of alarm and message relay functions

Programming of alarm relay in: PROGRAMMING: 16 ALARM RELAY

Programming of message relay in: INTERFACE: 1 MESSAGE RELAY

- A** Display of error summary report (relay programmed as ERROR resp. ERROR inverse)
- F** Display FAN-ON (relay programmed : „FAN“)
- ↑** Display SUPPLY real power (relay programmed: „SUPPLY“)
- U** Display UNDER CURRENT
- H** HARMONIC
- OC** OVERCOMPENSATED
- UC** UNDERCOMPENSATED
- ⚡** SWITCHING OPERATIONS (no. of programmed relay switch.oper. exceeded)
- ME** MODBUS-ERROR or TSM-ERROR
- ⚡** C-DEFECT

By pressing the cursor buttons (up / down) the stage display mode can be changed

only available if control serie "E" is selected

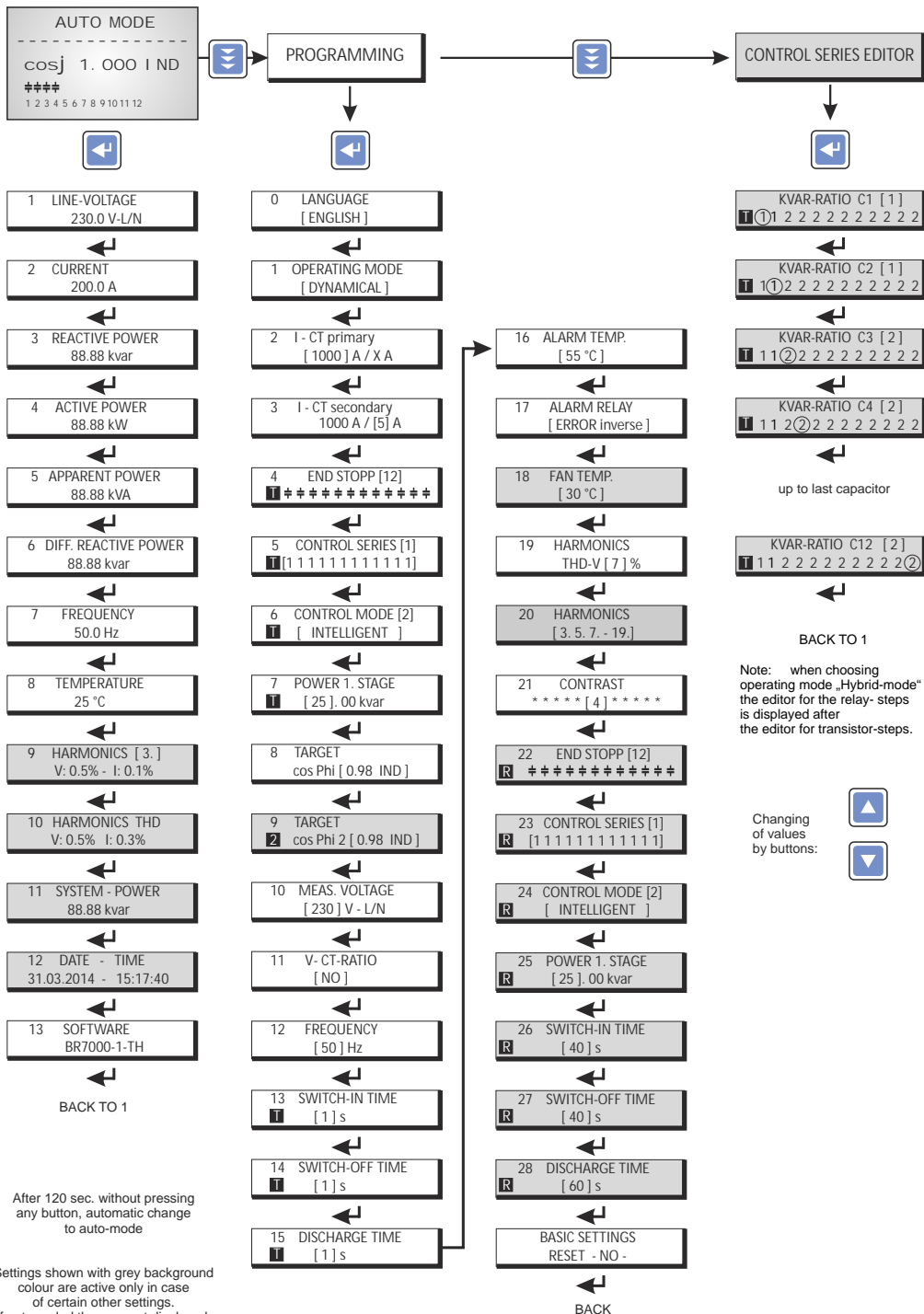

After 120 sec. without pressing any button, automatic change to auto-mode

Settings shown with grey background colour are active only in case of certain other settings. If not needed they are not displayed.

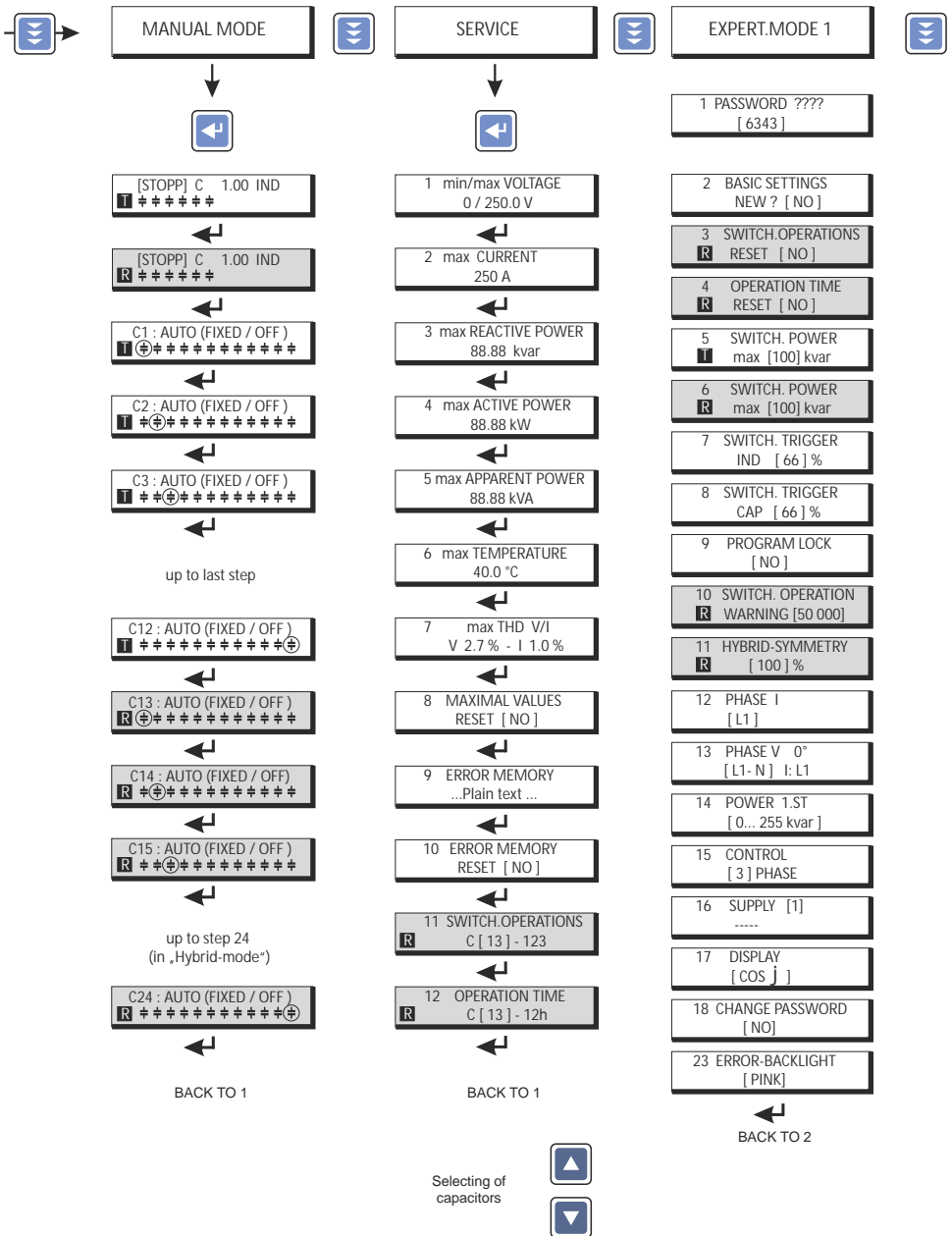

Operating diagram (brief programming)
Power Factor Controller BR 7000-1-TH/S485

