

TSM – LC100

Thyristor-Module for dynamic Power Factor Correction (PFC)

Version 1.2

Description

The TSM-LC for Dynamic PFC is a fast electronically controlled, self-observing thyristor switch for capacitive loads up to 100 kvar (380 / 400 VAC) which is capable to switch PFC capacitors within a few milliseconds as often and as long as required without abrasion.

Triggering can be done by means of dynamic power factor controllers, programmable logic controllers (PLC) or directly out of the technologic process.

Features

- Component for the design of Dynamic PFC-systems in 380V and 400V-grids
- Automatically adapted by microprocessor to de-tuned and conventional capacitor branches (up to 14%); therefore optimization of the switching behavior.
- Available for max. 100 kvar
- Monitoring of voltage, phase sequence, temperature; display of status via LED
- Switching without time lag
- No system perturbation caused by switching operations (no transients)
- Maintenance free
- Long operational life
- High switching speed
- No noise during switching
- Compact design,
- Forced cooling by fan, temperature controlled
- Ready for connection

Application:

Dynamic („real time“) PFC for fast processes, e.g.

- pressing
 - welding machines
 - elevators
 - cranes
 - wind turbines etc.
- with fast changing and high fluctuating loads.

Installation and connection

The mechanical mounting is done directly on a mounting plate. The main terminals are designed as bus bars and can be directly connected via conductors with cable lugs to the branch fuse resp. to the capacitor.

Connection is done according picture 1. It is mandatory to use superfast electronic fuses as branch fuses of the TSM-LC-module to protect the semiconductor device! Basics of dimensioning must be obeyed!

Triggering of the module is taking place without any time delay by a 10 – 24 VDC signal (coming from the PFC-controller or an adequate control system) fed in at the connection X1 (signal). If an increase of the stage output is needed, a cascading of several modules is possible.

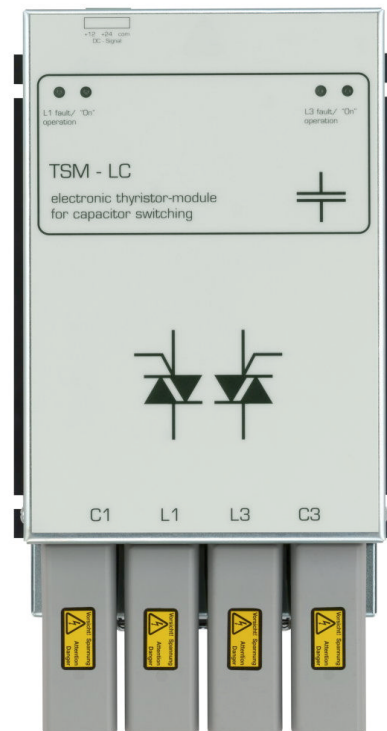

Putting into operation

After switching on the net voltage (engaging of the branch fuse) the thyristor module is ready for operation. Following tests and settings are performed when switching on the net voltage:

- control of control voltage (operating voltage module)
- automatic setting to net frequency (50 or 60 Hz)

When switching on the net voltage the first time, the internal processor will optimize the switching behavior to the connected steps (without reactors / de-tuned). This results in optimized switching times during operation later. These parameters are internally stored.

For each phase the thyristor module has 2 status-LEDs with the following meaning:

LED „fault/operation“ (green/red):

| | |
|-----------------------|--|
| green: | operating voltage activated, thyristor module standby |
| red is flashing fast: | temperature failure |
| red is flashing slow: | net voltage L1-L3 too low (under-voltage < 300 V) |
| permanent red: | phase L2 missing or under-voltage or phase L1 or L3 missing or capacitor without capacitance or not existent |

LED "On" (yellow): "Module ON"

Technical Data

| | |
|--|---|
| Net voltage: | 380 ... 400 V – 50/60Hz |
| Max. power: | TSM-LC 100: 75 -100 kvar |
| Activation: | 10...24 VDC (20mA), via terminal clamp; internally insulated |
| Switching-on time: | app. 5 ms |
| Re-switching time: | Depending on degree of de-tuning and dimension of discharge resistor |
| Display: | via 2 LEDs per Phase: operation/error , triggering signal |
| Monitoring: | permanent monitoring of net voltage, temperature and operation status Note: Before re-switching after temperature fault, heat sink temperature must be below 50 °C (hysteresis)! |
| Power circuit: | direct connection 4-pole via bus bar (cable lug 70qmm D=10mm) Connection from bottom |
| Aux. supply: | 230 VAC (needed for fan) via terminal clamp Automatically controlled cooling, Overtemperature switch-OFF |
| Max. RMS-current*: | 200A * no continuous current – thermal load has to be considered! |
| Max. voltage: | - in conventional PFC-systems (without reactors): 440V - de-tuned 7%: 440 V (no upwards tolerance permitted) - de-tuned 14%: 400 V |
| Power dissipation: Thermal warming: | $P_v (W) = 2,0 \times I (\text{ in A })$; at 400V / 100kvar typical 300 W 20 K over ambient temperature at nominal load |
| Fuses: | 3 x electronic fuse „superfast“ (NH1 AC 690V) 100 kvar: 250 A (e.g. SIBA Art.No.: 20 211 20-250) |
| Dimensions: Weight : | 157 x 240 x 195 (w x h x d) 5.5 kg |
| Assembling : | direct mounting on mounting plate |
| Mounting position : | vertical, minimum 100mm distance upwards and downwards |
| Operating ambient temperature with nominal load: | -10°C ... 55°C |

Pic. 1:
 Connecting diagram
 Three-phase load
 (Standard)

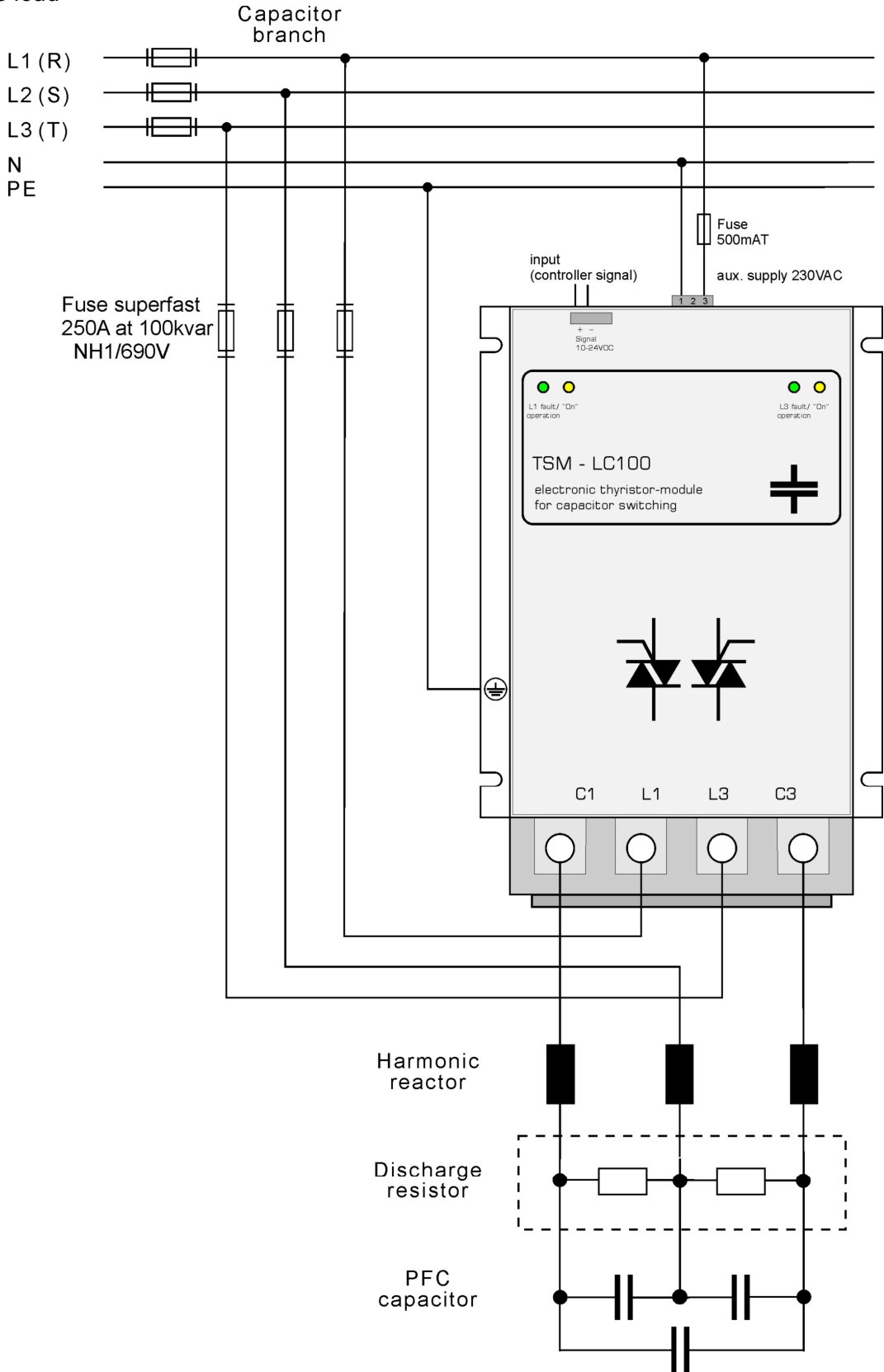



Attention: Please follow SAFETY INSTRUCTIONS !

GENERAL:

- The TSM-LC-thyristor-modules may only be used according their intended utilization.
- The TSM-LC-thyristor-modules must only be used in combination appropriate safety devices (e.g. superfast fuses).
- The TSM-LC-thyristor-modules have to be projected in such a way that no uncontrolled high currents and voltages can occur in case of faults.
- The devices have to be protected against humidity and dust – a sufficient ventilation has to be assured.
- The TSM-LC-thyristor-modules must only be switched to the net if any harm or danger to human beings or the PFC-system is eliminated.

Due to the switching principle of the thyristor modules the PFC-capacitors are permanently loaded at the peak value of the grid voltage (DC current) even when they are disconnected! Therefore, the following instructions have to be obeyed:

- In non-detuned systems (400V grid) you need capacitors with a voltage of 440V!
In detuned systems (400V grid) you need capacitors with a voltage of 525V !
- For discharging the capacitors special high-voltage resistors are required (e.g. type EW22) Standard resistors cannot be used.
- In Dynamic PFC-systems with TSM-LC-thyristor-modules fast discharge reactors must not be used (reactor = direct current short circuit.)
- In non-detuned PFC-systems (without reactors) current limitation reactors per thyristor-module are mandatory!
- The TSM-LC-thyristor-modules have to be protected by superfast electronic fuses in any case. Dimensioning principles have to be observed. Fuses in the PFC-system must be marked!
- Due to the special switching the PFC-capacitors are fully loaded even if the step is switched off. An appropriate protection against touch must be assured!
- Even when electronic switches are turned off, no electrical isolation is given. Therefore even after switching off the complete PFC-system (main circuit breaker), parts of the PFC-system must only be touched after the discharge-time of the PFC-capacitor elapsed.
- In the PFC-system warning signs indicating the presence of residual voltage even at disconnected stage have to be visible.

MAINTENANCE, REPAIR

The TSM-LC-thyristor-switch has to be deactivated for maintenance purpose and main circuit breaker must be released. It must be assured that it cannot be switched on during maintenance. It must be checked that there is no voltage at all. Maintenance must only be executed by specially skilled personnel.

In case any repairs are needed, this must only be done from the manufacturers of the TSM-LC-thyristor-module!