

TSM-HV50

Thyristor-Module for dynamic Power Factor Correction (PFC) up to 60 kvar / 690V

Version 1.0

Description

The TSM-HV50 for Dynamic PFC is a fast electronically controlled self-observing thyristor switch for capacitive loads up to 60 kvar (690AC) which is capable to switch PFC capacitors within a few milliseconds as often and as long as required without abrasion.

Triggering can be done by means of dynamic power factor controllers, programmable logic controllers (PLC) or directly out of the technologic process.

Features

- Component for the design of Dynamic PFC-systems in 690V-grids
Neutral conductor required
- Micro-processor controlled alignment to tuned or de-tuned capacitor branches (up to 14%) for optimized switching behaviour.
- For capacitive loads up to 60 kvar at 690V
- Monitoring of voltage, phase sequence, temperature; display of status via LED
- No system perturbation due to switching operations (transients)
- Switching without delay
- Maintenance free
- Long useful service life
- No noise emission during switching operation
- Compact module ready for connection



Application:

Dynamic („real time“) PFC for fast processes in 690V grids, e.g.

- pressing
- welding machines
- elevators
- cranes
- wind turbines etc.
with fast changing and high fluctuating loads.

Installation and connection

The mechanical mounting is done directly on a mounting plate. The main terminals are designed as bus bars and can be directly connected via conductors with cable lugs (25 qmm) to the branch fuse resp. to the capacitor.

Connection is done according picture 1. It is mandatory to use superfast electronic fuses as branch fuses of the TSM-HV-module to protect the semiconductor device! Basics of dimensioning must be obeyed!

Triggering of the module is taking place without any time delay by a 10 – 24 VDC signal (coming from the PFC-controller or an adequate control system) fed in at the connection X1 (signal). If an increase of the stage output is needed, a cascading of several modules is possible.

Putting into operation

After switching on the net voltage (engaging of the branch fuse) the thyristor module is ready for operation.

When switching on the net voltage the first time, the internal processor will optimize the switching behavior to the connected steps (without reactors / de-tuned). This results in optimized switching times during operation later. These parameters are internally stored.

For each phase the thyristor module has a status-LED with the following meaning:

green:	operating voltage activated, thyristor module standby
red is flashing:	auxiliary voltage (230V) too low
permanent red:	phase is missing or under-voltage or capacitor without capacitance or not existent

LED "On" means:	green: "Module ON"
	red: "overtemperature"

Technical Data

Net voltage:	max. 690 V – 50/60Hz
Auxiliary supply:	230 V~
Switching capability:	50A (max. 60 kvar at 690V)
Activation:	10...24 VDC (appr.20mA), via terminal clamp; internally insulated
Switching time:	appr. 5 ms
Re-switching time:	depending on degree of detuning and dimension of discharge resistor
Display:	via 4 LEDs : operation/error each phase, triggering signal, overtemp.
Monitoring:	permanent monitoring of net voltage, temperature and operation status
Power circuit:	direct connection 4-pole via bus bar (cable lug 25qmm D=8mm) Connection from bottom
Power dissipation:	$P_v (W) = 3.0 \times I (\text{in A})$; at 690V / 50kvar typical 125 W therm.
Fuses:	3 x electronic fuse „superfast“ (NH00 AC 690V) 50/60 kvar: 100 A (e.g. SIBA Art.No.: 20 209 20-100) 25 kvar: 63 A (e.g. SIBA Art.No.: 20 477 20-63)
Dimensions:	157 x 200 x 195 (w x h x d)
Mounting position :	vertical, minimum 100mm distance upwards and downwards
Weight :	5.0 kg
Assembling :	direct mounting on mounting plate
Operating ambient temperature with nominal load:	-10°C ... 55°C

Pic. 1:
 Connection diagram: Three-phase load at 690V (standard)

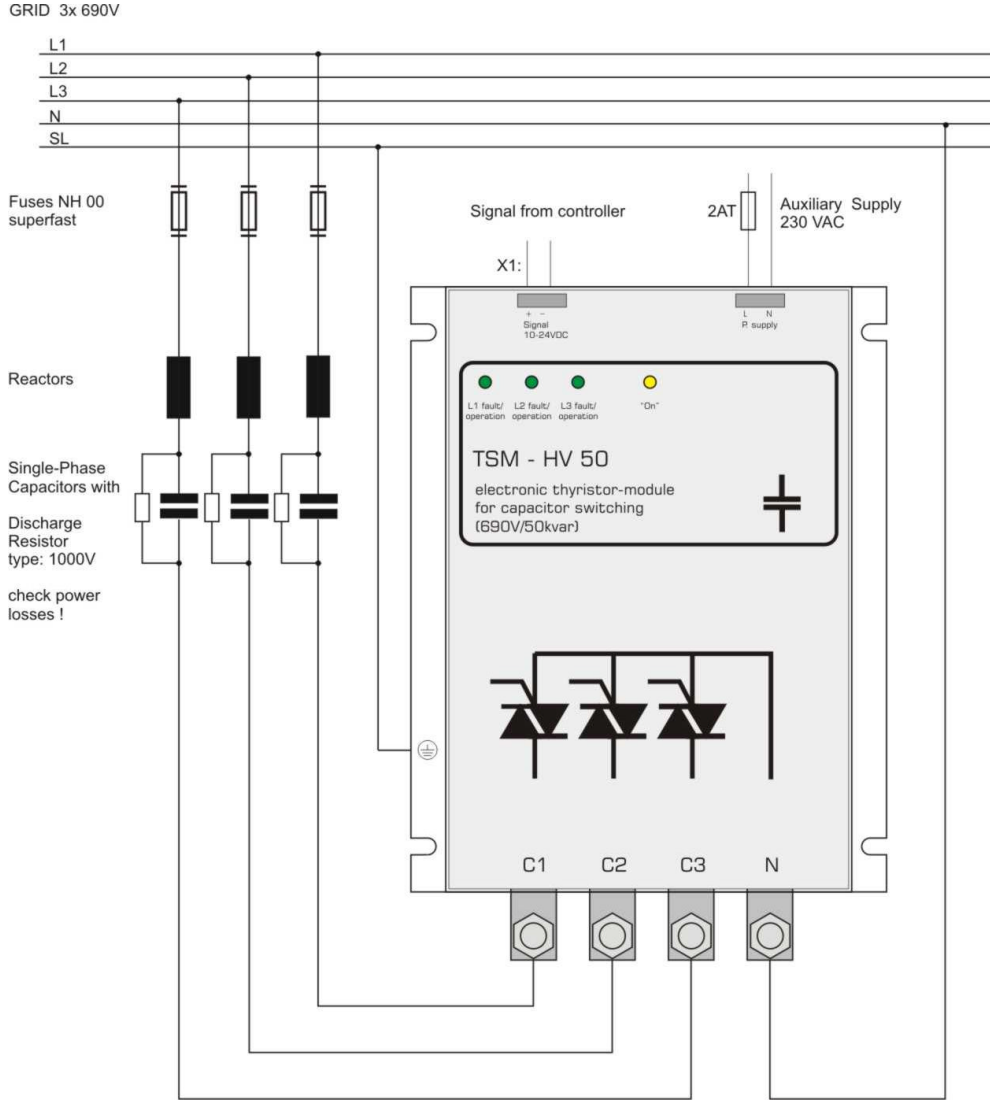

Attention: Please follow SAFETY INSTRUCTIONS !

GENERAL:

- Thyristor-modules may only be used for the purpose they have been designed for.
- Thyristor-modules may only be used in combination with appropriate safety devices (e.g. superfast fuses).
- Thyristor-modules have to be projected in such a way that in case of any failure no uncontrolled high current and voltages may occur.
- The devices have to be protected against moisture and dust – a sufficient cooling has to be assured.
- Thyristor-modules must only be switched to the net if any harm or danger to human beings or the PFC-system is eliminated.

Attention

Due to the switching principle of the thyristor module the power-capacitors are permanently loaded to the peak value of the grid voltage (DC voltage) even when switched off! Therefore, following rules have to be obeyed in any case:

- For tuned systems single-phase power capacitors of 400V nominal voltage have to be used; for de-tuned systems single-phase capacitors of 440V nominal voltage have to be used.
- In dynamic PFC-systems with TSM-modules no fast discharge reactors may be used (reactor = DC-wise short circuit.)
- For tuned PFC-systems (without reactors) per thyristor module 3 current limitation reactors are mandatory! Available as accessory (BD100).
- Thyristor-modules in general have to be protected by superfast electronic fuses. Principles for dimensioning have to be considered. Fuses in the system have to be marked!
- Due to the special switching, the PFC-capacitors are fully loaded even when the particular step has been switched off. Protection against contact has to be guaranteed. Warning signals in the system are required!
- Even in switched off state no electrical isolation is achieved for electronic switches. Therefore parts of the systems may not be touched after switching off the complete system before the capacitors have been completely discharged.

FAILURE TO FOLLOW CAUTIONS MAY RESULT, WORST CASE, IN PREMATURE FAILURES OR PHYSICAL INJURY.

MAINTENANCE, REPAIR

The thyristor-switch has to be deactivated for maintenance purpose and main circuit breaker must be released. It must be assured that it cannot be switched on during maintenance. It must be checked that there is no voltage at all. Maintenance must only be executed by specially skilled personnel.

In case any repairs are needed, this must only be done from the manufacturers of the TSM-thyristor-module!