

Application:
Coupling of 2 PFC-systems without retroactivity

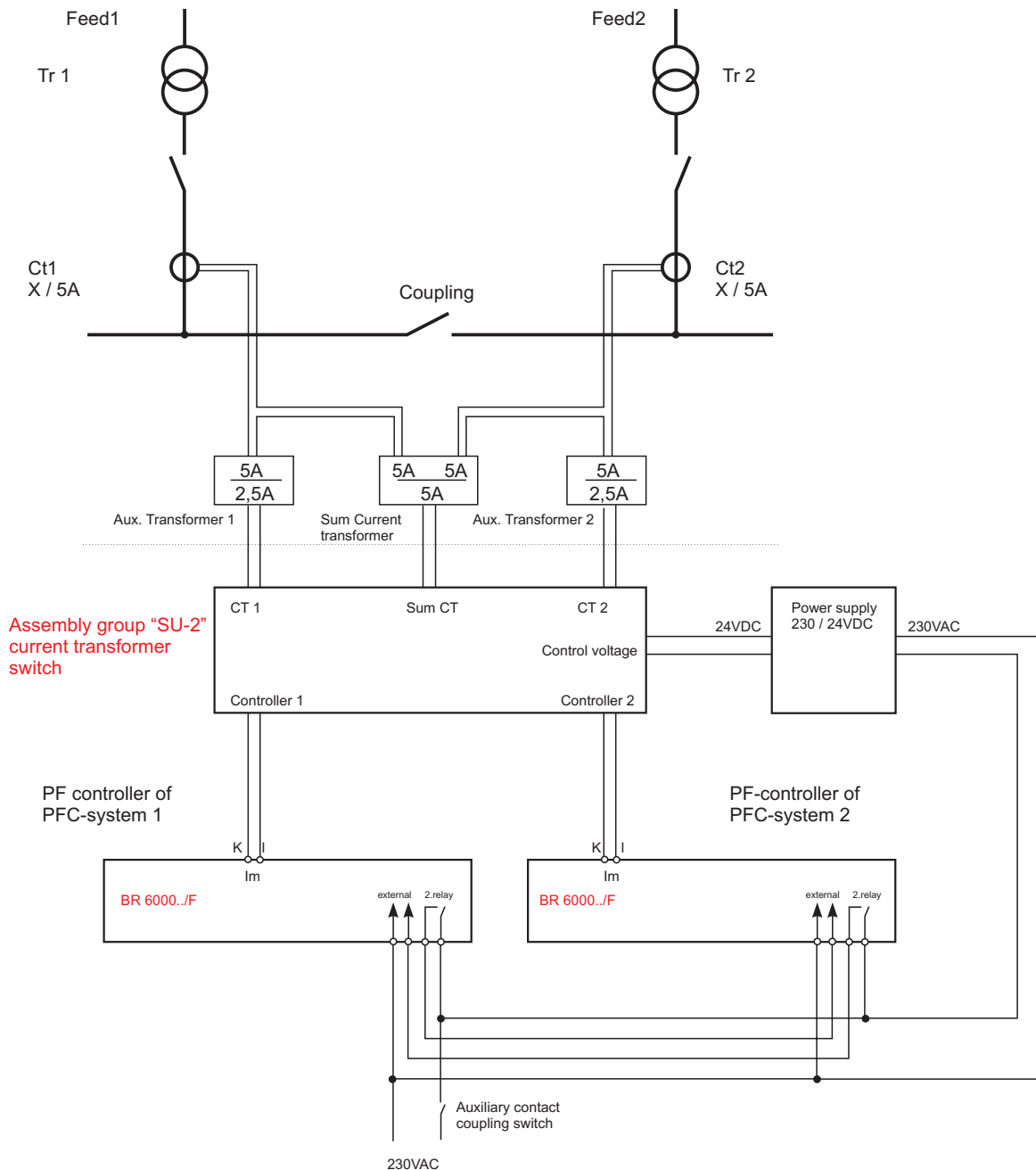

Function:

Operating status 1 (coupling switch open)

Both PFC-systems work separately on their respective feeders. Special accessory for coupling 2 PFC-systems is needed: The assembly group "SU-2" switches the particular current transformer input directly to the controller. The auxiliary contact of the coupling switch is opened – therefore no control coupling is taking place.

Operating status 2 (coupling operation on busbar) – coupling switch closed):

In this case the auxiliary contact of the coupling switch is closed. Voltage control applies to "SU-2". Sum current transformer is connected to measuring current inputs of both controllers (series connection). This ensures that the controllers measure the current of the whole PFC-system (feed-in 1 and 2). At the same time the PF-controller are switched to controller coupling. (This is done by the external switching according the drawing and only possible with BR6000 controller version ../F or ../S.). Now the PFC-systems work in master-slave-mode, means that all steps are switched to the 1. system and then further steps of the 2. system. This avoids a mutual interaction of the PFC-systems.

Note:

When programming the controller, it is determined which PFC-system for controller coupling will operate as master and which one will operate as slave.

The auxiliary current transformer 1 and 2 are used for adjusting of the measuring current in normal operation. Therefore no change of current transformer ratio has to be done when the sum current transformer is switched on. This has to be considered when programming the current transformer ratio at the controller.

Example: Current transformer 1 and 2 in the feed in are at 1000A/5A.

By means of the sum current transformer resp. the auxiliary transformers the controllers are programmed 2000A/5A.